

Write your name at the top right corner of every page (including this cover page).

Copy everything you want counted towards your grade onto the pages that I provided.

Write with a pen that cannot be erased!

No books are allowed!

Only the calculators I provided are allowed!

Write down all the steps that lead to your result.

Identify new variables that you may introduce in the circuit diagrams that I provided.

Read all the problems before you start so that you can begin with those that seem easiest to you.

To get smooth calculations please use the following values for the magnitude forward voltage drop between base and emitter when calculating the large signal response of bias of a BJT: **0.7 V** if active, or **0.8 V** if in saturation. $V_T = 26 \text{ mV}$.

MOSFET circuit symbols:

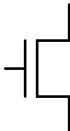
enhancement mode MOSFET 

depletion mode MOSFET 

Problem 1 (6 pts):

Find the Thevenin and the Norton Equivalents for the following circuit:

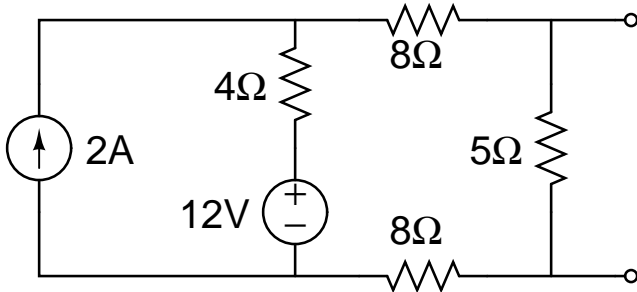

(continuation of problem 1)

Problem 2 (8 pts):

What are the voltages at the three Op-Amp outputs?

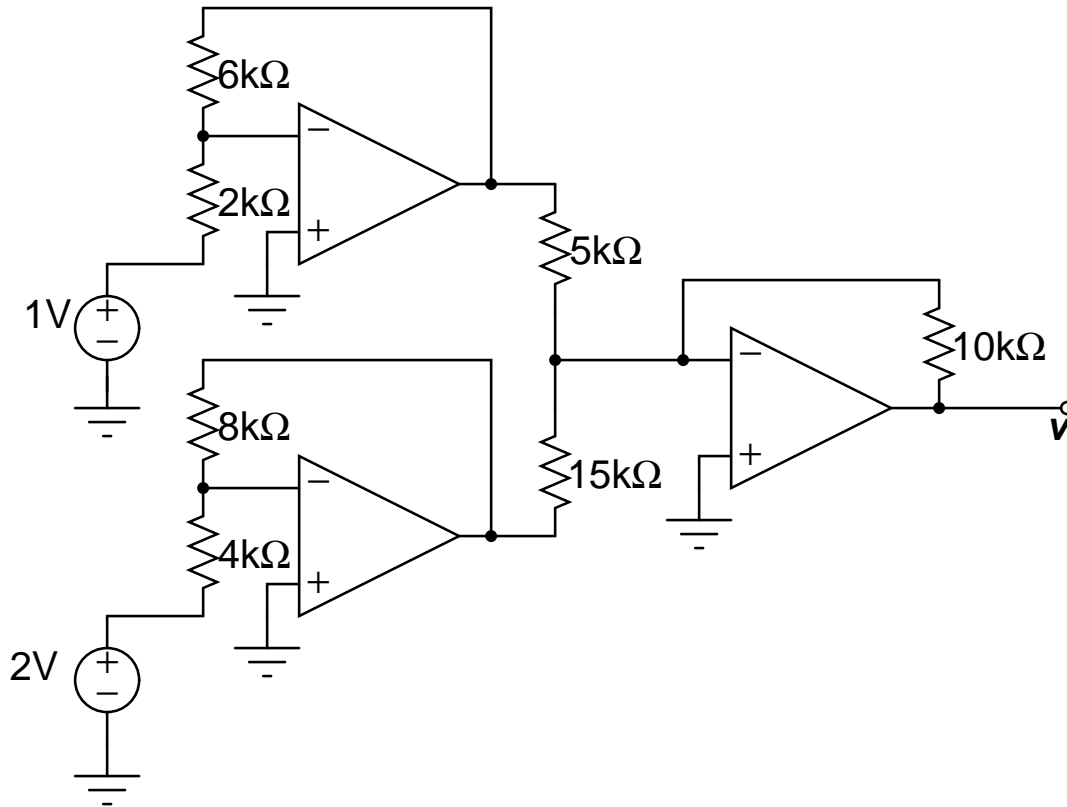

(continuation of problem 2)

Problem 3 (8 pts):

Write the Karnaugh map and analyze it to find an efficient(!) implementation for the following truth table:

A	B	C	D	F
0	0	0	0	1
0	0	0	1	0
0	0	1	0	1
0	0	1	1	0
0	1	0	0	1
0	1	0	1	1
0	1	1	0	0
0	1	1	1	0
1	0	0	0	1
1	0	0	1	0
1	0	1	0	1
1	0	1	1	0
1	1	0	0	1
1	1	0	1	1
1	1	1	0	0
1	1	1	1	0

(continuation of problem 3)

Problem 4 (7 pts):

Use only the straight-line asymptotes to sketch the Bode Plot (both, amplitude and phase!) for the transfer function:

$$H(j\omega) = \frac{j\omega}{a+j\omega} \text{ with } a > 0.$$

What type of filter is this?

(continuation of problem 4)

Problem 5 (6 pts):

Below you find an example of collector feedback bias. Assuming that the transistor is operating in its active region and has $\beta = 100$, find i_B , i_C , and v_{CE} . Confirm that the transistor is in the active region.

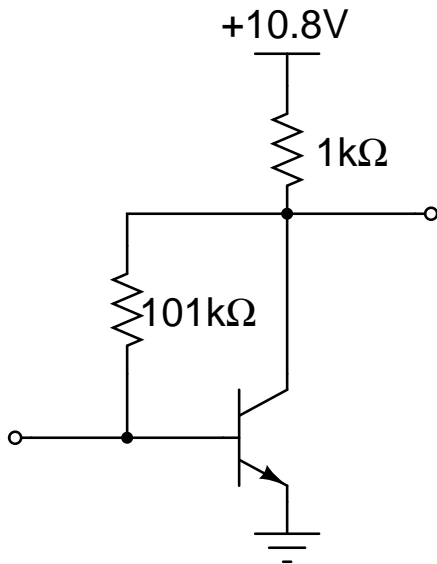

(continuation of problem 5)

Problem 6 (6 pts):

In the depletion-MOSFET circuit shown below the MOSFET has $I_{DSS} = 8\text{mA}$ and $V_p = -2\text{V}$. Find V_{GS} , i_D , V_{DS} , and confirm that the MOSFET is operated in the active region.

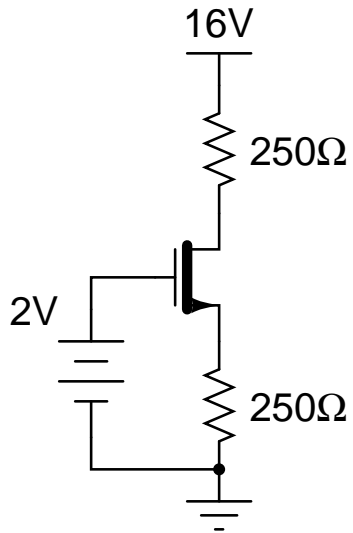

(continuation of problem 6)

Problem 7 ONLY 6610 students !!! (8 pts):

For the Darlington configuration below, find i_{B1} , if the transistors both have $\beta = 99$. i_{B1} is the base current into the first transistor. The first transistor is the one that has the second transistor's base connected to its emitter.

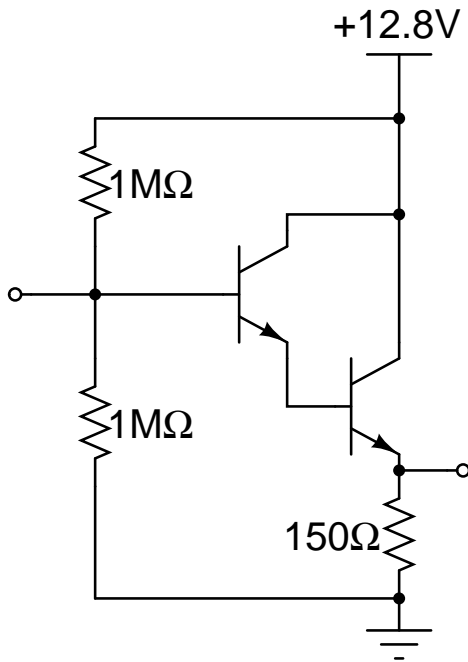

(continuation of problem 7)