

Write your name at the top right corner of every page (including this cover page).

Copy everything you want counted towards your grade onto the pages that I provided.

Write with a pen that cannot be erased!

No books or calculators are allowed!

Write down all the steps that lead to your result.

Identify new variables that you may introduce in the circuit diagrams that I provided.

Read all the problems before you start so that you can begin with those that seem easiest to you.

Problem 2 (8 pts):

Draw a circuit diagram for a circuit that would clamp a sinusoidal input waveform to sit on top of a +5V offset. Remember to make sure a current can always flow. Do not count on the load for this. If you use a diode, assume it is ideal - no forward voltage drop. With an ideal diode: does your circuit impose a restriction on the frequency of your input sinusoid? What is that restriction?

Problem 3 (8 pts):

Write the Karnaugh map and analyze it to find an efficient(!) implementation for the following truth table; derive the logic expression as a sum of products and draw the resulting circuit diagram:

A	B	C	D	F
0	0	0	0	1
0	0	0	1	1
0	0	1	0	1
0	0	1	1	0
0	1	0	0	0
0	1	0	1	1
0	1	1	0	0
0	1	1	1	0
1	0	0	0	1
1	0	0	1	1
1	0	1	0	0
1	0	1	1	1
1	1	0	0	0
1	1	0	1	1
1	1	1	0	0
1	1	1	1	1

(continuation of problem 3)

Problem 4 (6 pts):

Implement the logic function $F = (\overline{A} + \overline{B})(B + \overline{C})$ purely through NAND gates.

(continuation of problem 4)

Problem 5 (8 pts):

Find the input impedance of the following circuit at 50 rad/s:

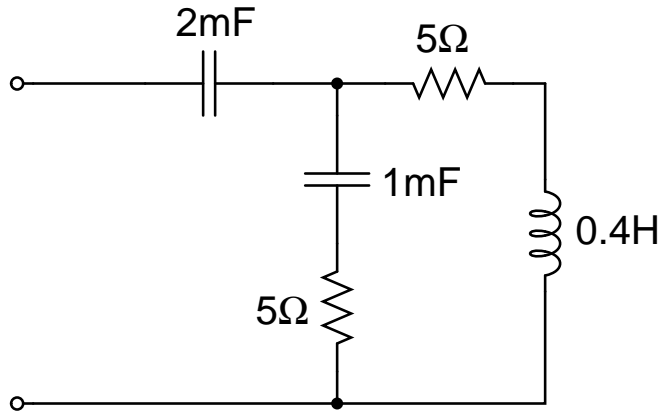

(continuation of problem 5)

Problem 6 ONLY 6610 students !!! (8 pts):

Determine v_L in the following circuit if $v_i = \sqrt{0.5} \sin(4 \text{ rad/s } t + \phi)$ with $\phi = 45$ degree:

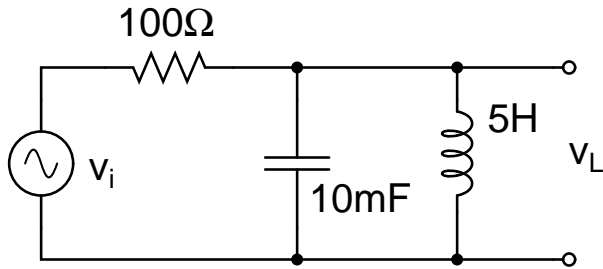

(continuation of problem 6)